

Network node

WTT56..



The WTT56.. network node is used to receive and handle the data transmitted by heat cost allocators, heat and water meters incorporated in a radio network.

- Storage of up to 500 metering devices
- Every network node installed in the system stores all consumption data of the entire system (mesh system)
- Secure data network: AES128 encryption, login and password
- Battery-powered



Use

The network node is a component of an M-bus radio network.

It receives the radio telegrams transmitted by the consumption meters and stores them locally. The WTT56.. can be read out either locally via M-bus or USB or from a remote location via gateway

Functions

Communication

Up to 12 network nodes can communicate with each other in a network and exchange the respective consumption data (mesh system). This way, up to 500 heat cost allocators and/or wireless heat/water meters can be incorporated in a radio network (management of 500 addresses). This means that each individual network node stores all consumption data of the entire network.

Data security

Communication between the network nodes can be encrypted with the help of an AES128 key. This key is preinstalled and can be activated if required.

Also, using individual login and a password, each network node can be protected against unauthorized access.

M-bus interface

The network node is equipped with an M-bus interface which can be used to incorporate the WTT56.. into a wired M-bus system. The interface also facilitates local data readout or parameterization of the network on site.

Socket for USB adapter

The network node has a 8-pole socket for connection of an external USB adapter RNNPH0010010. This adapter can be used to read out the network on site or to upload firmware updates to the network node.

IrDA interface

The IrDA interface can be used to teach in or out individual meters or – if there is a need to replace a complete network node – all data of the former network node can be transferred to the new node. In both cases, tools or extra software are not required.

Restrictions

Combined heat/cooling energy meters can have 2 identification numbers, one for heat and one for cooling energy. In this case, the network node handles the combined meter like 2 autonomous meters.

The network node consists of 2 major housing sections: The upper section with cover for wall mounting and the removable lower section.

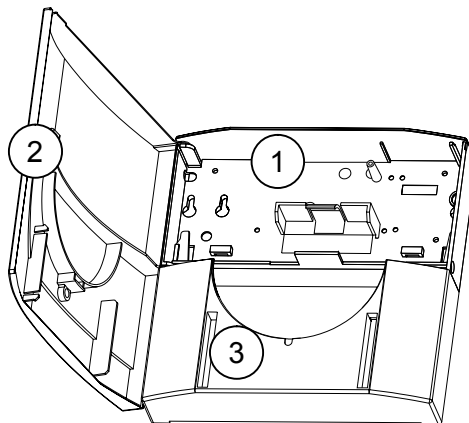

- (1) Upper section for wall mounting
- (2) Cover
- (3) Lower section

The upper section (1) only accommodates the main battery.
The lower section (3) contains the operating elements for the network.

Lower section

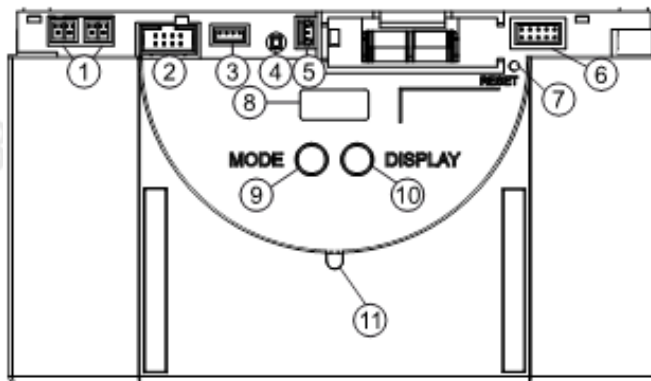

- 1. Socket for M-bus service connection
- 2. Socket for extension module
- 3. Socket for power supply DC 3.6 V
- 4. LED for indication of mains supply (lit only when mains-powered)
- 5. Socket for backup battery DC 3.6 V
- 6. Socket
- 7. Reset button (recessed)
- 8. Display
- 9. MODE button (red)
- 10. DISPLAY button (blue, for changeover)
- 11. IrDA interface (optical)

Backup battery

The backup battery ensures uninterrupted operation of the network node in the event of a temporary power failure (mains failure or when the main battery is replaced).

M-bus interface

Using socket (1), the M-bus can be permanently connected to the network node. The connector is part of the scope of delivery. An additional socket (2) is available for temporary connections (e.g. for service purposes).

Display

The WTT56.. network node features an LCD for reading a number of parameters and the error codes.

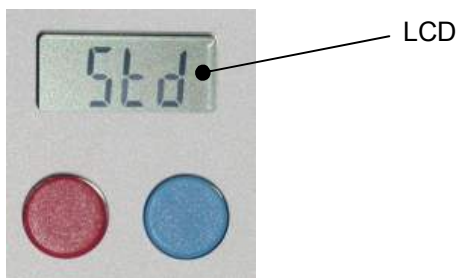

Type summary

The following products are available:

Type	Stock number	Designation
WTT561-AA1100	S55563-F137	Battery-powered network node

Delivery

The network node is supplied complete Mounting Instructions in several languages, two screws, two dowels, a m-bus plug and a jumper.

Accessories

Type	Stock number	Designation
WTZ.BAT	JXF:WTZ.BAT	Battery for WTT..
FBR0018	JXF:FBR0018	Backup battery for WTT561..

Programming accessories

Type	Stock number	Designation
RNNPH0010010	JXF:RNNPH0010010	USB adapter
WFZ.MBM-USB	JXF:WFZ.MBM-USB	M-bus programming adapter (USB)
RNNPH0020010	JXF:RNNPH0020010	M-bus adapter plug for WFZ.MBM-USB
ACT26	JXF:ACT26	Setup and service software

Equipment combinations

The WTT56.. network node is compatible with the following products:

Type	Designation
WTT16 WTT16.232 WTT16 WTT16.232	Network nodes (predecessor version)
WTT16.GSM WTT16.IP WTT16.MOD-1	Gateways (predecessor version)

Available product documentation

Topic	Title	Document ID
Mounting	Network node WTT56..	A6V10456410
Installation and operating	Network node WTT56..	A6V10456412

The mounting instruction is supplied with the network node.

Detailed Operating and Commissioning Instructions can be downloaded from the Internet (Siemens Download Center):

<http://www.siemens.com/btproduct?WTT561-AA1100>

Languages

The Mounting, Operating and Installation Instructions are supplied in 18 languages: Bulgarian, Croatian, Czech, Dutch, English, Finnish, French, German, Greek, Hungarian, Italian, Lithuanian, Norwegian, Polish, Slovakian, Slovenian, Spanish and Turkish.

Related documents can be downloaded at the following Internet address (Siemens Download Center):

<http://siemens.com/bt/download>

Notes**Commissioning****Commissioning and service software**

To upload firmware updates, to read out meter data or to parameterize the network, the ACT26 software is required.

Insert battery

For safety reasons, the network node is supplied without having the main battery fitted. As soon as the main battery is inserted, the network node calculates the battery's life.

Maintenance**Replacement of battery**

To replace an exhausted main battery, remove it and insert the new battery. The backup battery must not be removed at this time since this would lead to data loss!

Disposal

The device is considered an electronics device for disposal in terms of European Directive 2012/19/EU and may not be disposed of as domestic garbage.

- Dispose of the device through channels provided for this purpose.
- Comply with all local and currently applicable laws and regulations.
- Dispose of empty batteries in designated collection points.

Warranty

Technical data on specific applications are valid only together with Siemens products listed under "Equipment combinations". Siemens rejects any and all warranties in the event that third-party products are used.

Technical data

Power supply main battery	
Battery type	Lithium battery LSH20 (exchangeable)
Battery voltage	3.6 V
Battery life	Min. 5 years

Power supply backup battery	
Battery type	Lithium battery LS14500 (exchangeable)
Battery voltage	3.6 V
Battery life	Min.10 years

Display	
Display mode	4-digit LCD + pictograms

Interfaces		
Optical interface	Design	Similar to EN 62056-21
	Protocol	According to EN 13757-2/-3
M-bus- interface	Current draw	1 M-bus load
	Addressing	Primary or secondary
	Baud rate	300, 2400 or 9600 Baud
	Max. permissible readout frequency	Typically twice a day
Radio AMR	Protocol	According to EN 1434-3 and EN 13757-2/-3
	Frequency band	868.3 MHz with 1 % Duty Cycle
	Standards	Data transmission according to EN 13757-4
	Transmitter power (typically)	12 dBm

Protection classification	
Protection class	III according to EN 60730-1
Protection degree of housing	IP20 according to EN 60529

Ambient conditions			
	Operation	Transport	Storage
	EN 60721-3-3	EN 60721-3-2	EN 60721-3-1
Temperature	+5...55 °C	-20...70 °C	-20...60 °C
Humidity	<93% r.h.	<93% r.h.	<93% r.h.
Mechanical conditions	Class 3M3	Class 2M2	Class 1M2
Max. altitude	Min. 700 hPa, corresponding to max. 2,000 m above sea level		

Standards, directives and approvals	
Product norm	60950-1 IT equipment
EU conformity (CE)	8000079949 ¹⁾
Environmental compatibility	The product environmental declaration A6V10490437 ¹⁾ contains data on environmentally compatible product design and assessments (RoHS compliance, materials composition, packaging, environmental benefit, disposal).

External dimensions of the device	
Dimensions (W x H x D)	200 x 200 x 57.1 mm (see "Dimensions")
Housing - Material	PC+ABS
Housing - Color	RAL 9016
Weight	810 g (incl. package insert)

¹⁾ Documents can be downloaded from <http://siemens.com/bt/download>.

Dimensions

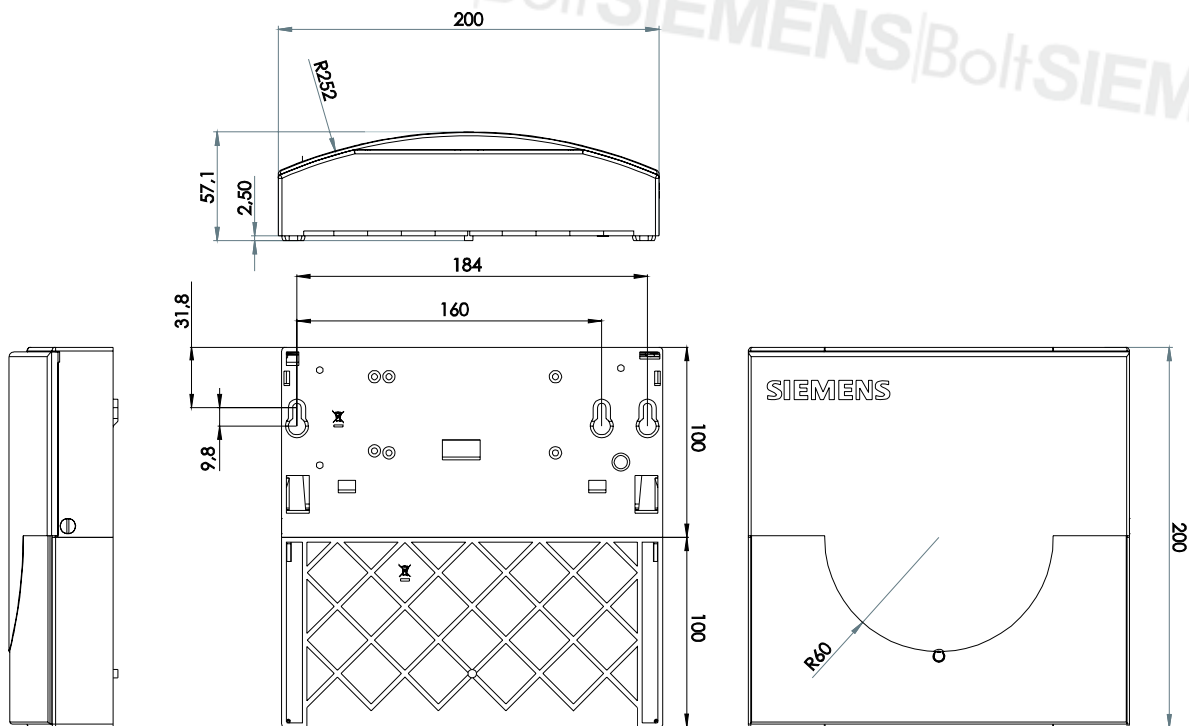

Dimensions in mm

SIEMENS|BoltSIEMENS|BoltSIEMENS|BoltSIEMENS|BoltSIEMENS

SIEMENS|BoltSIEMENS|BoltSIEMENS|BoltSIEMENS|BoltSIEMENS

Issued by
Siemens Switzerland Ltd
Building Technologies Division
International Headquarters
Gubelstrasse 22
6301 Zug
Switzerland
Tel. +41 41-724 24 24
www.siemens.com/buildingtechnologies

© Siemens Switzerland Ltd, 2015
Technical specifications and availability subject to change without notice.

Document ID A6V10455680_en--_c
Issue 2015-07-01