

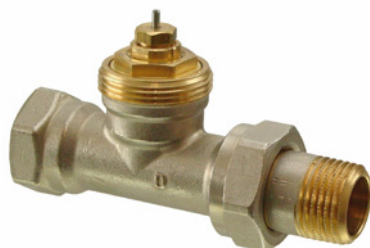

EN 215-1



Straight valves VDN1...



Angle valves VEN1...



Radiator Valves

DIN-norm, for 2-pipe heating systems

VDN1...
VEN1...

- Valve bodies made of brass, mat nickel-plated
- DN 10, DN 15 and DN 20
- Integrated presetting of the k_v -values
- Internally and externally threaded (Rp/R) conforming to ISO 7-1
- Manual knob / protective cover included in the delivery
- Can be combined with RTN... thermostatic actuators, SSA... motoric actuators or STA... and STS61... thermal actuators

Use

The radiator valves are used in hot water heating plants for individual room or zone temperature control and limitation. They are basically recommended in all rooms, especially where heat gains or different temperature levels occur.

Type summary

Type reference straight	Type reference angle	DN	k_v -value [m^3/h] setting range	k_v -value [m^3/h] at a P-band of 2 K
VDN110	VEN110	10	0.09...0.63	0.43
VDN115	VEN115	15	0.10...0.89	0.52
VDN120	VEN120	20	0.31...1.41	0.71

Order

When ordering, please give quantity, product name and type reference.
 Example: 2 straight valves VDN120
 1 protection against dismantling ATN2

Delivery

Valves and accessories are packed separately.

Equipment combinations

Product	Types	Data sheet
Thermostatic actuators	RTN...	N2111
Motoric actuators	SSA31... / SSA61... / SSA81...	N4893
Thermal actuators	STA21... / STA71...	N4877
Thermal actuators	STA72E...	N4875
Thermal actuators	STS61... ¹⁾	N4880

¹⁾ Quasi-proportional control action, not recommended for parallel operation

Function / mechanical design

The flow rate can be preadjusted with an orifice. Full stroke is ensured irrespective of the preadjustment, which is made with the help of the protective cover.

- 1 Manual knob / protective cover
- 2 Sealing gland
- 3 Valve insert
- 4 O-ring
- 5 Reset spring
- 6 Orifice

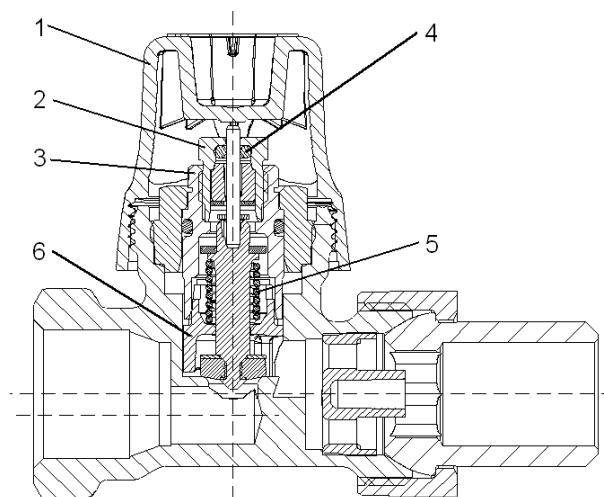

Features and benefits

- The valves conform to EN 215
- The sealing gland can be replaced while the plant is under pressure (no tools required)

Accessories

AVN1

Sealing gland



ATN2

Protection against dismantling



ATN3

Manual knob (RAL9016)



ATN4

Manual knob



AVN...

Compression fittings



Engineering notes

The reference numbers for preadjustment are given in the table with the k_v -values (see page 4) and in the valve sizing charts (see pages 5 – 6).

1. Calculate the volumetric water flow \dot{V}_{100}

$$\dot{V}_{100} = \frac{Q_{100}}{1.163 \times \Delta T \times f_1} \quad [\text{m}^3/\text{h}]$$

Q_{100} = heat demand [kW]
 ΔT = temperature differential [K]
 1.163 = constant of water
 f_1 = correction factor = 1 for water

2. Define the pressure drop Δp_{v100} across the fully open valve

In most types of plant, a differential pressure Δp_{v100} of 0.05 to 0.2 bar is adequate.

3. Calculation of the nominal flow value k_v

$$k_v = \frac{\dot{V}_{100}}{\sqrt{\Delta p_{v100}}} \quad [\text{m}^3/\text{h}]$$

Δp_{v100} = differential pressure across the valve [bar]

Example:

Heat demand	Q_{100}	= 1.2 kW
Temperature differential	ΔT	= 20 K
Water volume	$\dot{V}_{100} = \frac{1.2}{1.163 \times 20}$	= 0.052 m ³ /h = 52 l/h
Required differential pressure across the valve	Δp_{v100}	= 0.1 bar
Flow	$k_v = \frac{0.052}{\sqrt{0.1}}$	= 0.17 m ³ /h

Solution

According to the chart (refer to « Valve sizing charts», or table with k_v -values), the preadjustment required by a VDN110 3/8" valve is 2.

Tips

- Noiseless operation is ensured by a pump that provides no more pressure than is needed to transport the required amount of water.
- To keep the valve free from dirt particles, it is recommended to install a strainer.

k_v-values

The k_v value gives the volumetric water flow \dot{V}_{100} in m³/h at a pressure drop Δp_{V100} across the valve of 1 bar.

k_v-values [m³/h] at the different preadjusted positions

Control range with SSA..., STA... actuators and STS 61...	✓	✓	✓	✓	✓	✓	
Control range of thermostatic actuators RTN...	✓	✓	✓	✓	✓		✓
Reference numbers for preadjustment	1	2	3	4	5	N	N¹⁾
VDN110 / VEN110	0.09	0.18	0.26	0.33	0.48	0.63	0.43
VDN115 / VEN115	0.10	0.20	0.31	0.45	0.69	0.89	0.52
VDN120 / VEN120	0.31	0.41	0.54	0.83	0.91	1.41	0.71

¹⁾ k_v-value at a P-band of 2 K

Setting the k_v-values

The k_v-values can be set on the valve's head in 5 steps + N (fully open) using the protective cover, which can be turned through 180°.



Observe marking on the valve's outlet side!

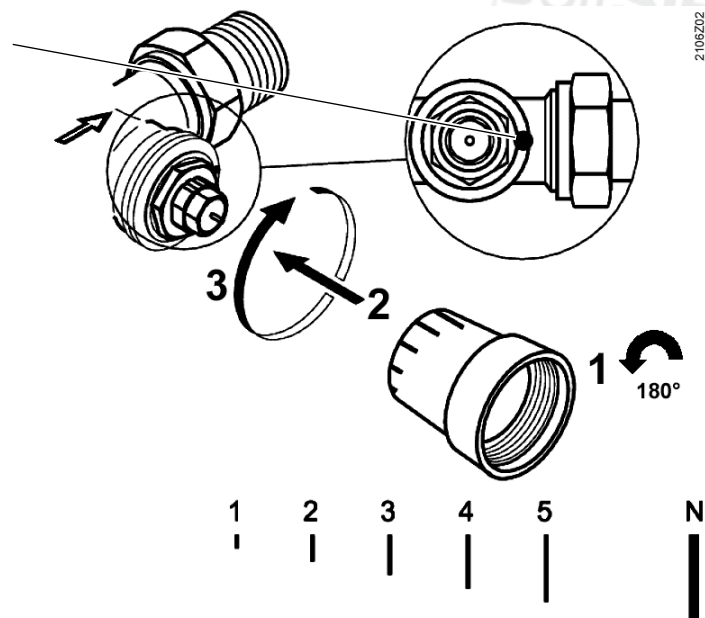

Valve sizing charts

VDN110
VEN110

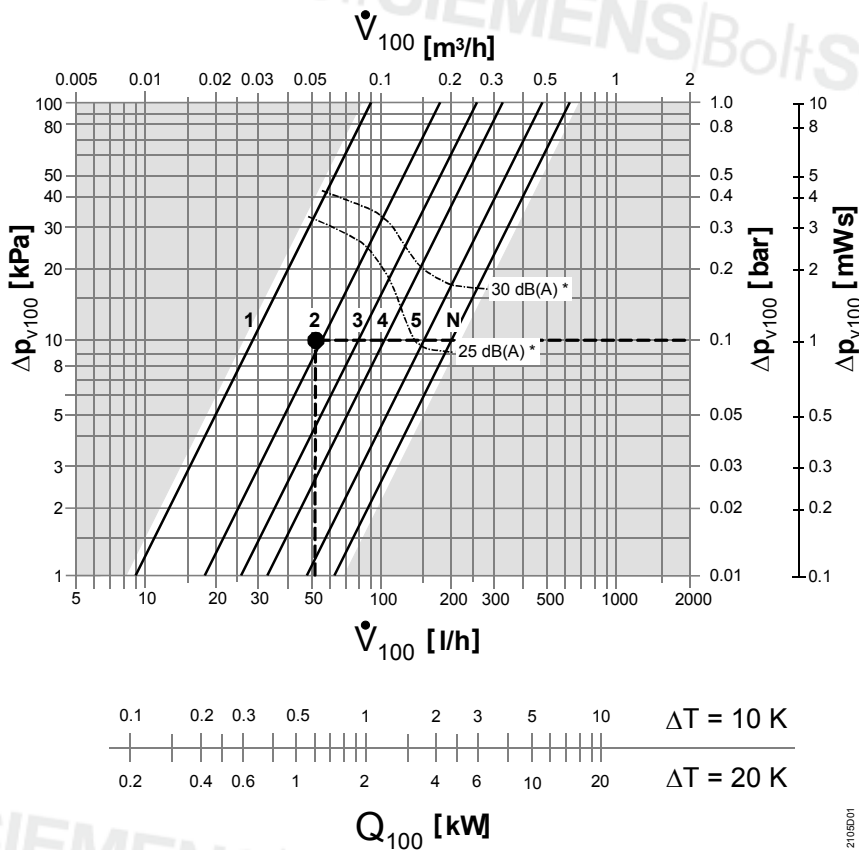

2105001

VDN115
VEN115

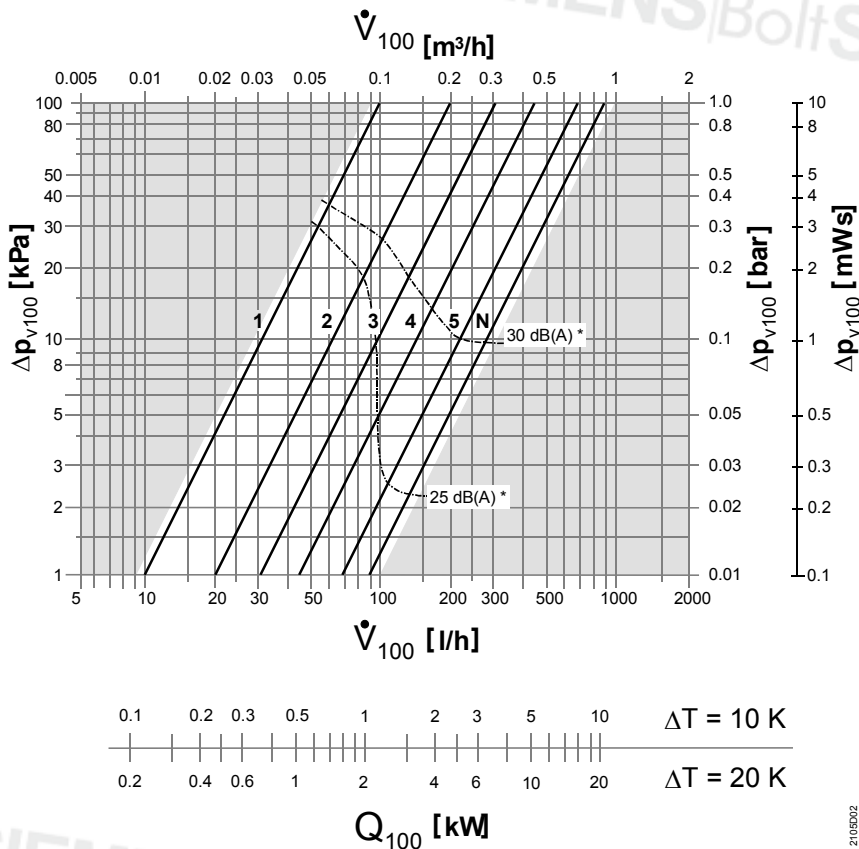

2105002

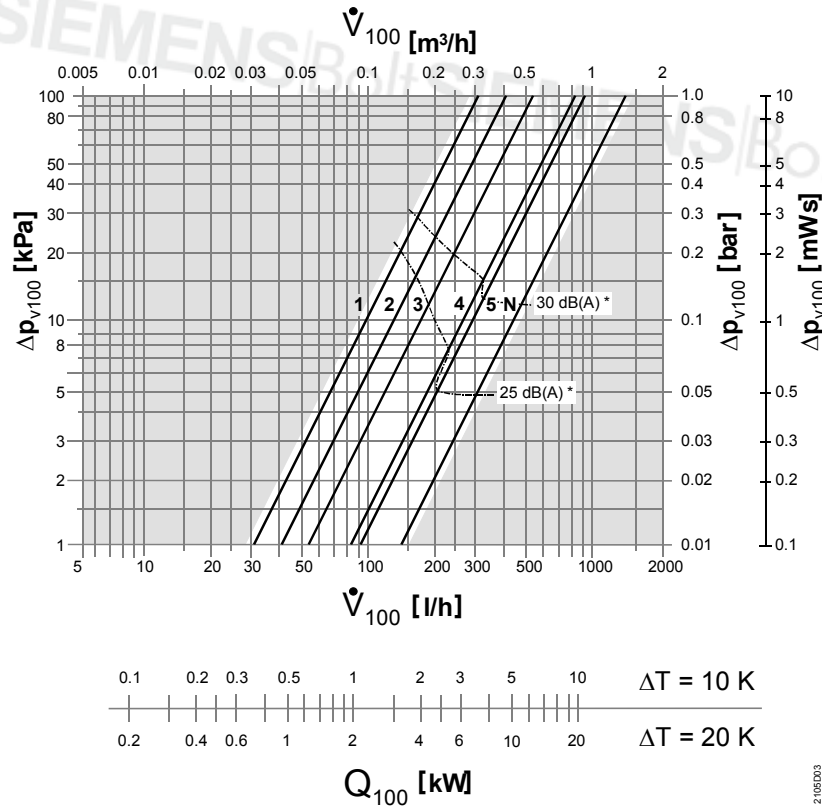

*) Measuring conditions of the noise curves on request.

Notes

Mounting

- Mounting Instructions are printed on the package
- The valves are supplied preadjusted to N (fully open)
- To ensure correct functioning of the thermostatic heads and electronic actuators, observe the available mounting choices and mounting conditions

Orientation

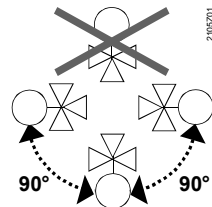

Maintenance

The valves are maintenance-free.

Repair

In the event of leakage, the valve's sealing gland can be replaced.
The valves cannot be repaired; the complete unit must be replaced.

Disposal

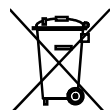

The valve must not be disposed of together with domestic waste.
Legislation may demand special handling of certain components, or it may be sensible from an ecological point of view.

Current local legislation must be observed.

Warranty

Application-related technical data are only warranted when used in connection with the Siemens controllers and actuators listed under «Equipment combinations».

When using the valves with actuators of other manufacture proper functioning must be ensured by the user. Any warranty by Siemens Switzerland Ltd / HVAC Products becomes void.

Technical data

Functional data

PN class	PN 10
Suitable media ¹⁾	cold and low-temperature hot water, water with propylene-glycol, water with ethylene-glycol < 30%; recommendation: water treatment to VDI 2035
Medium temperature	1...120 °C
Perm. operating pressure	1000 kPa (10 bar)
Differential pressure Δp_{max}	max. 60 kPa (0.6 bar)
Differential pressure Δp_{v100}	5...20 kPa (0.05...0.2 bar): recommended range
Stroke	min 1.2 mm

Materials

Valve body	brass, mat nickel-plated
Fitting	brass, mat nickel-plated
Protective cover	polypropylene
O-ring	EPDM, NBR

Dimensions / weight

refer to «Dimensions»		
Mounting length	EN 215	
Thread	Rp internally threaded	to ISO 7-1
	R externally threaded	to ISO 7-1
	G-thread	to ISO 228-1

¹⁾ Prefer propylene-glycol for environment protection reasons.

Dimensions

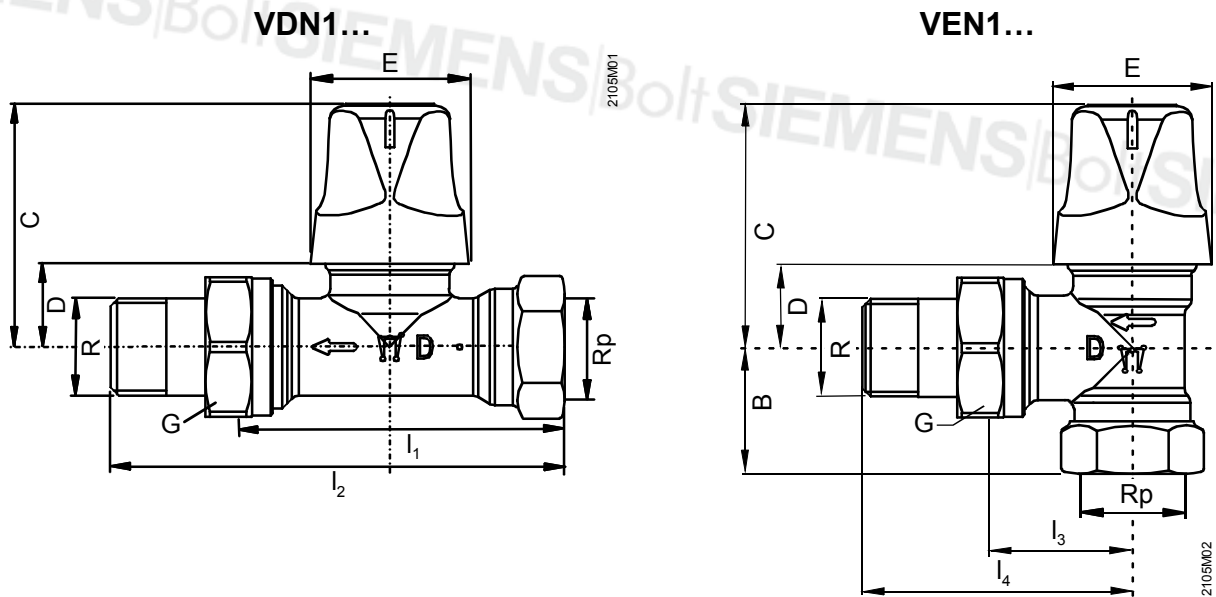

Type	DN	Dimensions [mm]							Thread [inch]			Weight [kg]	
		I ₁	I ₂	I ₃	I ₄	B	C	D	E	Rp	R		G
VDN110	10	59	85				53	18	35	3/8	3/8B	5/8	0.240
VDN115	15	66	95				53	18	35	1/2	1/2B	3/4	0.285
VDN120	20	74	107				53	18	35	3/4	3/4B	1	0.410
VEN110	10			26	52	22	53	18	35	3/8	3/8B	5/8	0.225
VEN115	15			29	58	26	53	18	35	1/2	1/2B	3/4	0.270
VEN120	20			34	66	29	53	18	35	3/4	3/4B	1	0.375

SIEMENS|Bolt SIEMENS|Bolt SIEMENS|Bolt SIEMENS|Bolt SIEMENS

SIEMENS|Bolt SIEMENS|Bolt SIEMENS|Bolt SIEMENS|Bolt SIEMENS

SIEMENS|Bolt SIEMENS|Bolt SIEMENS|Bolt SIEMENS|Bolt SIEMENS