



## Gas Burner Control

## LFL1.148

### Gas burner control

- for atmospheric gas burners in intermittent operation
- flame supervision with ionization probe

The LFL1.148 and this Data Sheet are intended for use by OEMs which integrate the burner controls in their products!

### Use

- For the supervision of 1- or 2-stage atmospheric gas burners
- For use with medium- to high-capacity burners
- For intermittent operation (at least 1 controlled shutdown in 24 hours)
- The gas burner has a connection facility for an auxiliary fan or flue gas fan (e.g. for condensing boilers)

Flame supervision is ensured by means of an ionization probe, 1 electrode is used for the first stage and 1 for the second stage. Changeover takes place automatically after release of the second fuel valve.

## Supplementary documentation

| Product type | Type of documentation | Documentation number |
|--------------|-----------------------|----------------------|
| LFL...       | Data sheet            | N7451                |

## Warning notes



To avoid injury to persons, damage to property or the environment, the following warning notes must be observed!

### Do not open, interfere with or modify the unit!

- All activities (mounting, installation and service work, etc.) must be performed by qualified staff
- **For safety reasons – self-test of the flame supervision circuit, etc. – at least one controlled shutdown must take place every 24 hours**
- Before performing any wiring changes in the connection area of the LFL1.148, completely isolate the unit from the mains supply (all-polar disconnection)
- Ensure protection against electric shock hazard by providing adequate protection for the burner control's connection terminals
- Each time work has been carried out (mounting, installation, service work, etc.), check to ensure that wiring is in an orderly state and make the safety checks as described in *Commissioning notes*
- Press the lockout reset button only manually (do not apply a force of more than 10 N) without using any tools or pointed objects
- Do not press the lockout reset button on the unit or the remote lockout reset button for more than 10 seconds since this would damage the lockout relay inside the unit
- Fall or shock can adversely affect the safety functions. Such units must not be put into operation, even if they do not exhibit any damage

## Mounting notes

- Ensure that the relevant national safety regulations are complied with
- Connect the earthing lug inside the terminal base to burner ground using a screw with a lockwasher or similar

## Installation notes

- Always run the high-voltage ignition cables separately while observing the greatest possible distance to the unit and to other cables
- Do not mix up live and neutral conductors

## Electrical connection of the ionization probe

It is important to achieve practically disturbance- and loss-free signal transmission:

- Never run the ionization cable together with other cables
  - Line capacitance reduces the magnitude of the flame signal
  - Use a separate cable of low capacitance
- The ionization probe is not protected against electric shock hazard
- Locate the ignition electrode and the ionization probe such that the ignition spark cannot arc over to the ionization probe (risk of electrical overloads)

## Commissioning notes

- Prior to commissioning, check to ensure that wiring is in an orderly state
- When commissioning the plant or when doing maintenance work, make the following safety checks:

|    | Safety check to be carried out                    | Anticipated response                    |
|----|---|---|
| a) | Burner startup with ionization cable disconnected | Lockout at the end of safety time (TSA) |

## Standards and certificates



### Applied directives:

- Low-voltage directive 2014/35/EC
- Directive for gas-fired appliances 2009/142/EC
- Directive for pressure devices 2014/68/EC
- Electromagnetic compatibility EMC (immunity) \*) 2014/30/EC

\*) The compliance with EMC emission requirements must be checked after the burner control is installed in equipment

Compliance with the regulations of the applied directives is verified by the adherence to the following standards / regulations:

- Automatic burner control systems for burners and appliances burning gaseous or liquid fuels DIN EN 298
- Safety and control devices for gas burners and gas burning appliances DIN EN 13611
- Automatic electrical controls for household and similar use Part 2-5: Particular requirements for automatic electrical burner control systems DIN EN 60730-2-5

**The relevant valid edition of the standards can be found in the declaration of conformity!**



### Note on DIN EN 60335-2-102

Household and similar electrical appliances - Safety - Part 2-102: Particular requirements for gas, oil and solid-fuel burning appliances having electrical connections. The electrical connections of the LFL1.148 and the AGM comply with the requirements of EN 60335-2-102.



EAC Conformity mark (Eurasian Conformity mark)



ISO 9001:2008  
ISO 14001:2004  
OHSAS 18001:2007



China RoHS  
Hazardous substances table:  
<http://www.siemens.com/download?A6V10883536>

Certified complete with plug-in base:



## Life cycle

---

Burner controls has a designed lifetime\* of 250,000 burner startup cycles which, under normal operating conditions in heating mode, correspond to approx. 10 years of usage (starting from the production date given on the type field). This lifetime is based on the endurance tests specified in standard EN 298 and the table containing the relevant test documentation as published by the European Association of Component Manufacturers (Afecor) ([www.afecor.org](http://www.afecor.org)).

The designed lifetime is based on use of the burner controls according to the manufacturer's Data Sheet. After reaching the designed lifetime in terms of the number of burner startup cycles, or the respective time of usage, the burner control is to be replaced by authorized personnel.

\* The designed lifetime is not the warranty time specified in the Terms of Delivery

## Disposal notes

---

The unit contains electrical and electronic components and must not be disposed of together with domestic waste.  
Local and currently valid legislation must be observed.

## Mechanical design

---

The mechanical design of the LFL1.148 corresponds to that of the standard units of the LFL range (refer to Data Sheet N7451).

## Type summary

---

The type reference given below apply to the LFL1.148 without plug-in base and without flame detector. For ordering information for plug-in bases and other accessories, see *Accessories*.

**Gas burner control**, without plug-in base

**LFL1.148**

Article no.: **BPZ:LFL1.148**

Plug-in base not included in the delivery, must be ordered as a separate item!

## Accessories (to be ordered separately)

---

### Flame detector

### Ionization probe

To be supplied by thirds



### Connection accessories for medium-capacity burner controls

Plug-in base **AGM410490550** with Pg11 threads for cable entry glands.

Article no.: **BPZ:AGM410490550**

Refer to Data Sheet N7230

Plug-in base **AGM14.1** with M16 threads for cable entry glands.

Article no.: **BPZ:AGM14.1**

Refer to Data Sheet N7230



## Technical data

For technical data – with the exception of the data listed below and the switching times of the switching mechanism – refer to Data Sheet N7451.

### General unit data

Perm. length of detector cable

- Normal cable, laid separately Max. 50 m
- Shielded cable, shielding connected to terminal 22, e.g. high-frequency cable Max. 100 m

Capacity

- Output on startup (without fan assistance) Any (with ignition < 120 kW)
- Nominal output Any

### Environmental conditions

#### Storage

DIN EN 60721-3-1  
Climatic conditions Class 1K3  
Mechanical conditions Class 1M2  
Temperature range -20...+60 °C  
Humidity <95% r.h.

#### Transport

DIN EN 60 721-3-2  
Climatic conditions Class 2K2  
Mechanical conditions Class 2M2  
Temperature range -40...+60 °C  
Humidity <95% r.h.

#### Operation

DIN EN 60 721-3-3  
Climatic conditions Class 3K5  
Mechanical conditions Class 3M2  
Temperature range -20...+60 °C  
Humidity <95% r.h.  
Installation altitude Max. 2,000 m above sea level



#### Warning!

Condensation, formation of ice and ingress of water are not permitted!  
If not observed, there is a risk of impairment of safety functions and of electric shock hazard.

## Function

---

In terms of control program and flame supervision (including test of the flame supervision circuit), the functions of the LFL1.148 correspond of those of the standard units of the LFL range.

There is a difference however in the control of actuator (SA) and of load controller (LR), especially with regard to the air damper position on startup and closing of the air damper during controlled shutdown.

Supervision of the respective start position is accomplished via an auxiliary switch in the damper actuator whose contact must be included in the start control loop between terminals 4 and 5.

It must be ensured that the current path between terminals 4 and 5 remains closed until controlled shutdown takes place.

During controlled shutdown, the air damper is driven to the fully closed position via contact (VIb) of the switching mechanism.

Since the switching mechanism of the burner control does not continue to run until changeover of limit switch (z) in the air damper actuator occurs, the running time of actuator (SA) is optional.

The pilot flame is supervised by ionization probe (ION1), the main flame by ionization probe (ION2).



### **Warning!**

**On completion of the ignition safety time (TSA), a flame signal must be present at terminal 23 (ION1). On completion of the second safety time (t9), a flame signal must also be present at terminal 24 (ION2).**

In the event of fault and lockout indication:

- ◀ **No start**  
For example: Start control loop interrupted via actuator (SA)
- **Lockout** due to a fault in the flame supervision circuit
- ▼ **Abortion of startup sequence** because the auxiliary switch in actuator (SA) has cut the start control loop
- 1 **Lockout**, because no flame signal was present on completion of the ignition safety time (TSA)
- 2 **Lockout** because no flame signal was present on completion of the second safety time
- █ **Lockout** because the flame signal was lost during burner operation
- ◀ **Lockout** on completion of the control program, due to extraneous light or a faulty flame signal  
For example: Flame not extinguished

After the reset, the burner control's switching mechanism first returns to the start position and then initiates a burner restart.

Connection diagram

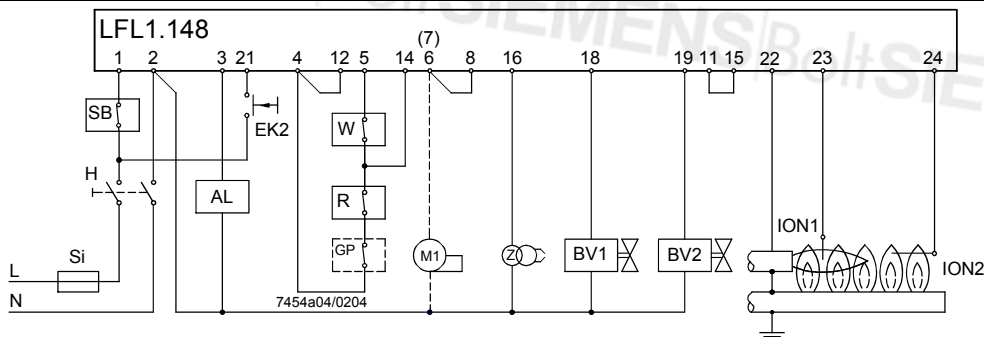

Connection examples

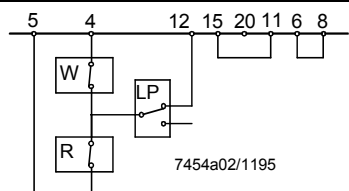

2-stage forced draft gas burner without load controller (LR) and without actuator (SA)

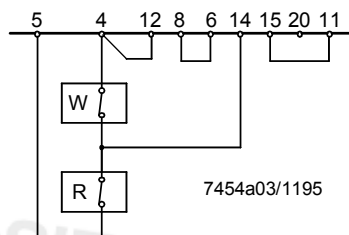

Atmospheric gas burner without fan assistance, load controller (LR) and actuator (SA)



# Basic diagram

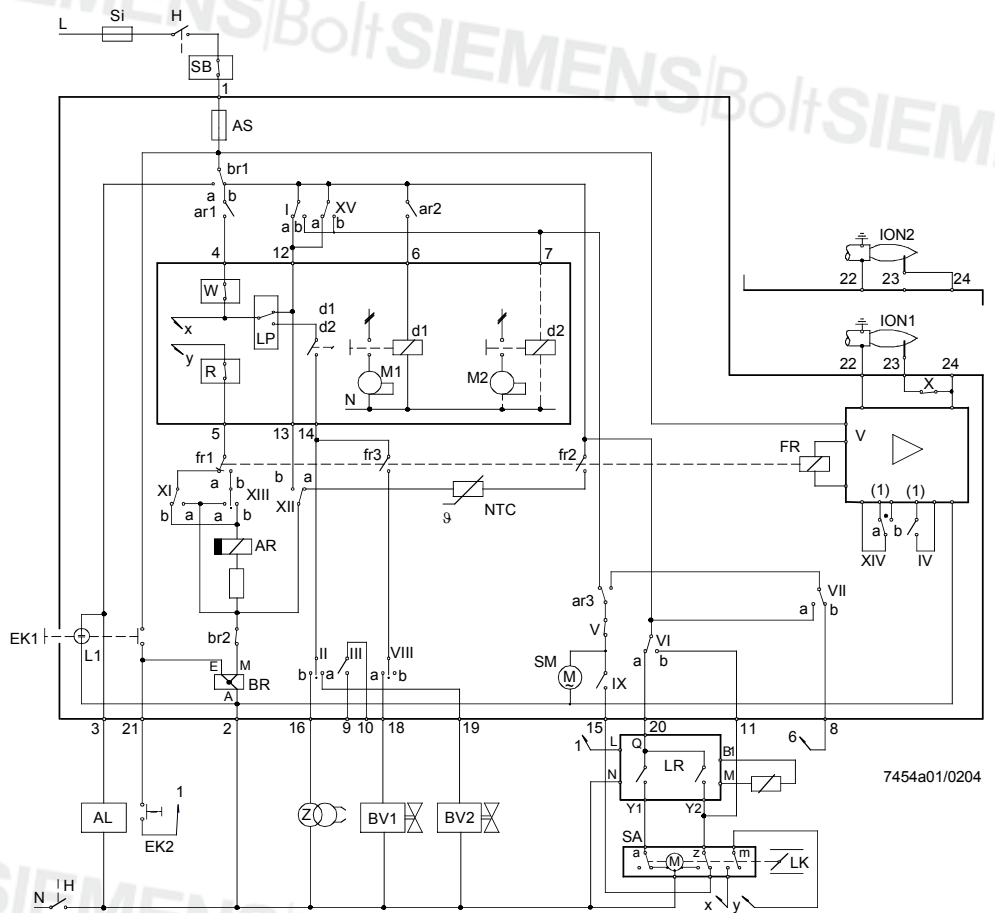

**Warning!**  
Do not press reset bottom (EK) for more than 10 seconds!

# Control program

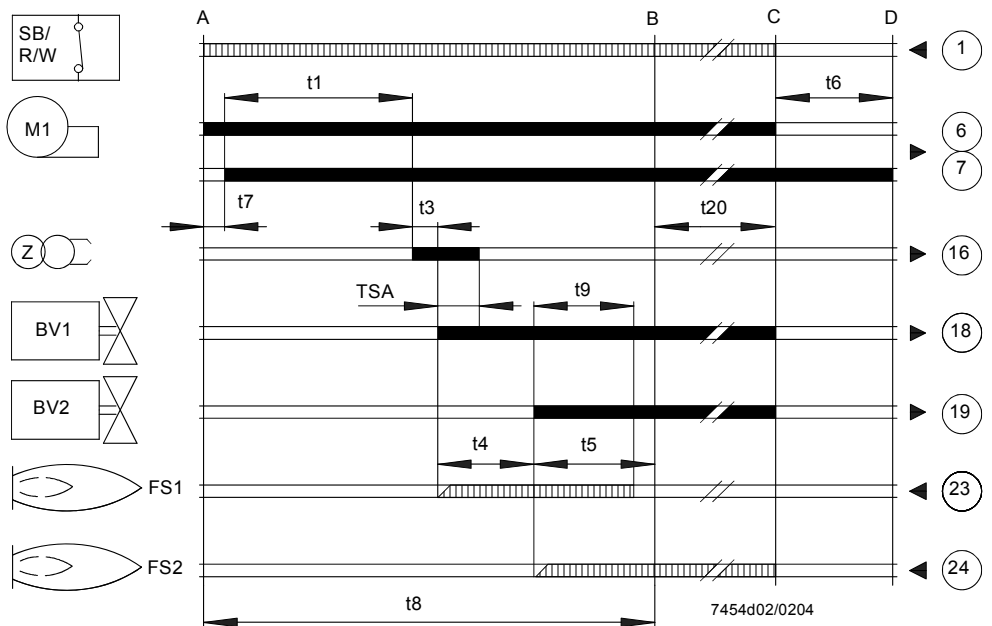

## Diagram of switching mechanism

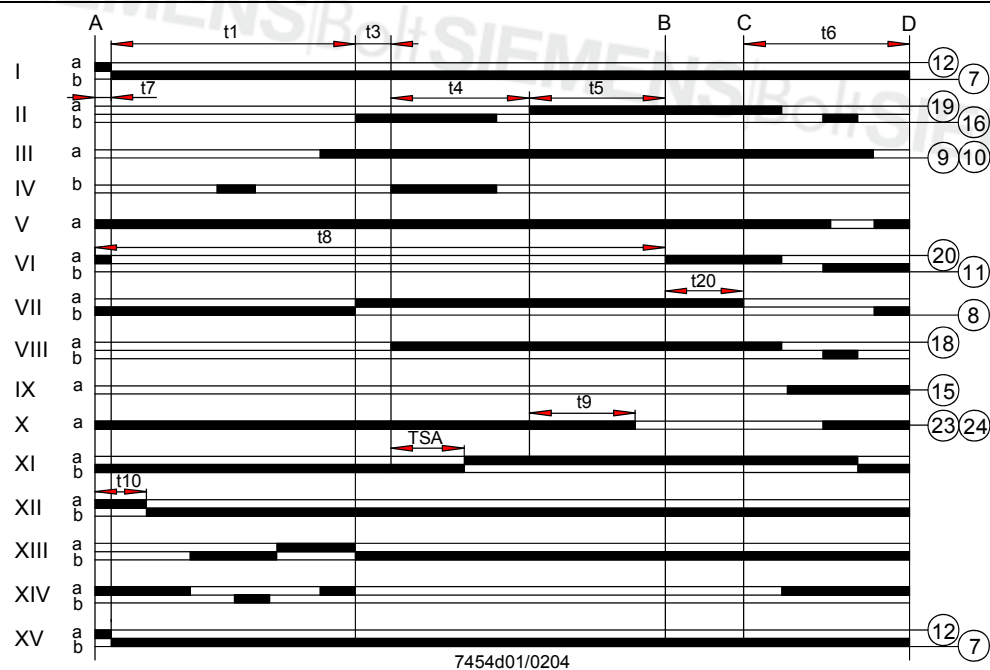

### Legend

|       |  |
|-------|--|
| AL    | Remote lockout indication → Alarm  |
| AS    | Unit fuse  |
| AR    | Main relay with contacts «ar...» → Working relay   |
| BR    | Lockout relay with contacts «br...»  |
| BVx   | Fuel valve   |
| d1/d2 | Contact or relay   |
| EKx   | Reset button   |
| IONx  | Ionization probe   |
| FR    | Flame relay with contacts «fr...»  |
| GP    | Gas pressure switch  |
| H     | Main isolator  |
| L1    | Lockout warning lamp   |
| LK    | Air damper   |
| LP    | Air pressure switch  |
| LR    | Load controller  |
| M1/M2 | Fan or burner motor  |
| NTC   | NTC resistor   |
| R     | Control thermostat or pressurestat   |
| SA    | Air damper actuator  |
| a:    | Changeover limit switch for actuator's OPEN position   |
| z:    | Changeover limit switch for actuator's CLOSED position   |
| SB    | Safety limit thermostat  |
| Si    | External primary fuse  |
| SM    | Synchronous motor of sequence mechanism  |
| V     | Flame signal amplifier   |
| (1)   | Input for forced energizing of the flame relay during the functional test of the flame supervision circuit (contact «XIV») and during safety time (TSA) (contact «IV») |
| W     | Limit thermostat or pressure switch  |
| Z     | Ignition transformer   |

|     |   |
|-----|---|
|     | Output signals of burner control  |
|     | Required input signals  |
| A   | Start command given by the control thermostat   |
| A-B | Startup sequence  |
| B   | Operating position of burner  |
| B-C | Burner operation  |
| C   | Controlled shutdown by control thermostat or pressurestat (R)   |
| C-D | Sequence mechanism runs to the end position after a controlled shutdown by control thermostat or pressurestat (R) |
| D   | End position of burner → Corresponding to the start position  |

### Switching times in seconds

|     |   |      |
|-----|---|------|
| TSA | Ignition safety time  | 4 s  |
| t1  | Waiting time or prepurge time   | 14 s |
| t3  | Preignition time  | 2 s  |
| t4  | Interval fuel valve (BV1-BV2)   | 8 s  |
| t5  | Interval between release of the 2 <sup>nd</sup> fuel valve and the load controller (if present) | 10 s |
| t6  | Postpurge time  | 10 s |
| t7  | Interval until voltage at terminal 7 is present   | 2 s  |
| t8  | Duration of startup program   | 36 s |
| t9  | 2 <sup>nd</sup> safety time for 2 <sup>nd</sup> stage   | 8 s  |
| t10 | Interval until air pressure check is started  | 6 s  |
| t20 | Steps of switching mechanism with no change in the program → Idle steps                         | 26 s |

Dimensions

Dimensions in mm

LFL1.148



Plug-in base AGM410490550 /  
AGM14.1

