

## Test unit for LOA2, LOA3, LMO14, LMO24, LMO44, LMO54, and LMO64 oil burners controls

## KF8885

Product documentation



The KF8885 and this product documentation are intended for original equipment manufacturers (OEMs) and their service personnel.

### Use

The KF8885 can be used for the following tests on LOA and/or LMO oil burner controls:

- For measuring the light detector current without modifying the wiring
- For purging the oil system
- For monitoring the ignition spark via the burner control without delay caused by oil preheating
- For measuring the fan pressure using a separate pressure gage without delays caused by oil preheating

### Warning notes



To avoid injury to persons, or damage to property or the environment, the following notes should be observed.

- To avoid the risk of electric shock:
  - For all work in the connection area of the oil burner control and the KF8885, disconnect the units from the mains supply completely
  - It is not permitted to open, interfere with or modify the unit
- It is also essential to observe the notes in the data sheets for the respective burner controls under all circumstances

### Service notes

- Only use the KF8885 test unit for service and maintenance work.
- Service and maintenance work may only be carried out by qualified staff.
- Test units with clear signs of damage must not be put into operation.
- Remove the KF8885 test unit from the burner plant once work is complete and it is no longer in use.

### Design

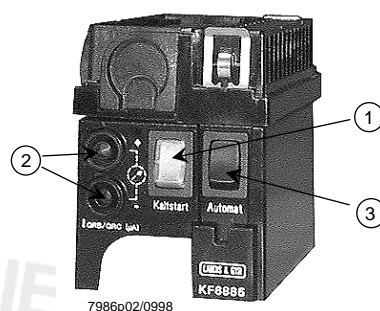

- ① Switch «S1» «Kaltstart» (cold start) with integrated lamp for indication of operational readiness
- ② Jacks «Bu1» for controlling the detector current
- ③ Switch «S2» «Automat» (burner control)

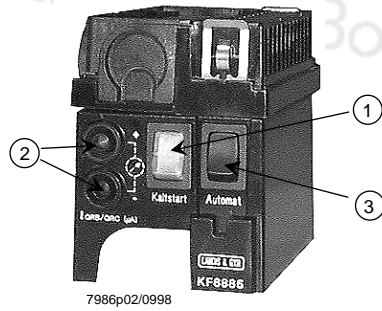

- ① Switch «S1» «Kaltstart» (cold start) with integrated lamp «L1» for indication of operational readiness
- ② Jacks «Bu1» for controlling the detector current
- ③ Switch «S2» «Automat» (burner control)

**Measure jacks for controlling the detector current**

These facilitate the measurement of the light detector current by means of separate DC microammeter without the need to intervene in the wiring.  
If the DC microammeter is not connected, a double-insulated bypass cable is required via either jack 1 (front of the unit) or jack 2 (rear of the unit).

**Switch «S1» «Kaltstart» (cold start)**

**Position I «Kaltstart» (cold start) active**  
Immediate cold start without oil preheating time.  
  
While «S2» is not closed, only the fan motor is controlled and the oil line purged.  
The burner control program only starts when «S2» is closed.

**Position 0 «Kaltstart» (cold start) not active**  
Normal start, with oil preheating according to the oil preheating time.

**Operational readiness lamp**

This indicates the voltage at terminal 8 on the unit, i.e., signals that the oil preheater is ready for heating.

**Switch «S2» «Automat» (burner control)**

**Position I «Automat» (burner control) active**  
Burner control is ready for operation.  
It starts when oil preheating is available, either with or without a delay, depending on the position of the switch «S1» «Kaltstart» (cold start).

**Position 0 «Automat» (burner control) not active**  
The burner control prevents burner startup; only the burner motor can be started via switch «S1» «Kaltstart» (cold start).  
This prevents the ignition release and valves release from being enabled unintentionally.  
This is the correct position for purging the oil lines.

**Wiring diagram**

**Detector current measurement QRB/QRC**

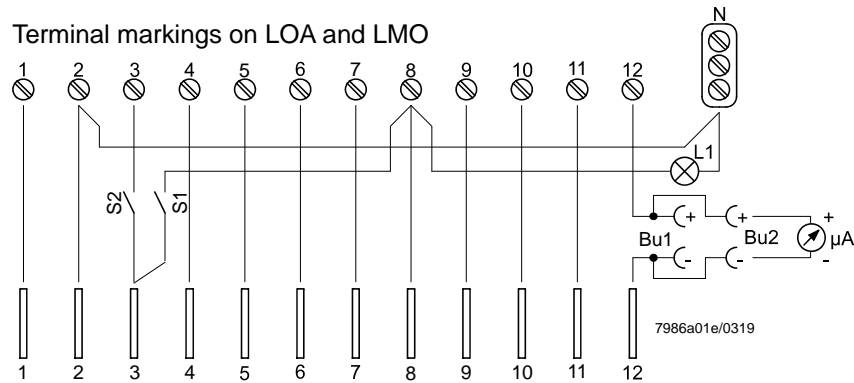

Contact blade marking for basic socket on the burner

**Key**

- Bu1 Ø 4 mm jacks on the front of the unit
- Bu2 Ø 4 mm jacks on the rear of the unit
- S1 Switch «Kaltstart» (cold start)
- S2 Switch «Automat» (burner control)
- L1 Lamp integrated into «S1»
- µA DC microammeter with internal resistance  $R_i = \text{max. } 5 \text{ k}\Omega$

Detector current required, refer to the data sheet for the respective burner control.