

Modulating control valve PN16 with magnetic actuator

M3P80FY
M3P100FY

for hot and chilled water
with positioning control and position feedback



Mixing or straight-through valves DN80 and DN100 with magnetic actuator for modulating control of hot and chilled water systems.

- Fast positioning time (1 s)
- High resolution (> 1 : 1000)
- 1 → 3 closed when de-energised
- With positioning control and position feedback
- Low friction, robust and maintenance-free

Use

The M3P...FY valves are mixing or through port valves with a ready-mounted magnetic actuator. The actuator is equipped with connecting electronics for positioning control and position feedback. If the power is off, the valve control path 1 → 3 is closed.

Warning : The valve is suitable for straight-through or three-way applications and may be installed **ONLY** in a mixing arrangement.

The short positioning time, high resolution and high rangeability make these valves ideal for proportional control of hot and chilled water systems.

The low-friction, robust and maintenance-free construction make regular service unnecessary.

Type summary

The M3P...Y valve is available in two sizes:

- M3P80FY** Flanged valve with DN80
M3P100FY Flanged valve with DN100

Flanged valves up to DN65 and screwed valves up to DN50 see sheet CA1N4455E.

Operating data

Valve type	DN [mm]	kvs [m ³ /h]	Δp _{max}		PN [VA]	P _{med} [VA]	q [mm ²]		
			[kPa]	[bar]			1.5	2.5	4.0
M3P80FY	80	80	300	3	80	20	10	16	27
M3P100FY	100	130	200	2	120	30	6	10	17

Legend:

- kvs = Flow rate to VDI/ VDE2173, tolerance ±10 %
- Δp_{max} = Max. admissible pressure differential
- PN = Nominal power
- P_{med} = Mean operating power
- q = Cross section of cable (Cu)
- L = Max. cable length. With 4-wire connections, the maximum permissible length of the separate 1.5 mm² Cu signal cable is 200 m.

Ordering

The valves are supplied complete with the magnetic actuator and the terminal housing. The blank flanges required for straight-through applications must be ordered separately (see 'Accessories').

When placing an order, please specify the quantity, product description and type code.

Example: 1 flanged valve M3P80FY and 1 blank flange Z155/80

Technical / Mechanical design

See data sheet CA1N4028E for a detailed description of operation.

The control signal is converted in the terminal housing into a phase cut signal which generates a magnetic field in the coil. This causes the armature to change its position in accordance with the interacting forces (magnetic field, counterspring, hydraulics etc.). The armature responds rapidly to any change in signal, transferring the corresponding movement directly to the control disc, enabling fast changes in load to be corrected quickly and accurately.

The valve position is measured continuously. Any disturbance in the system is rapidly corrected by the internal positioning controller, which ensures that the control signal and the valve stroke are exactly proportional, and also provides a feedback signal indicating the valve position.

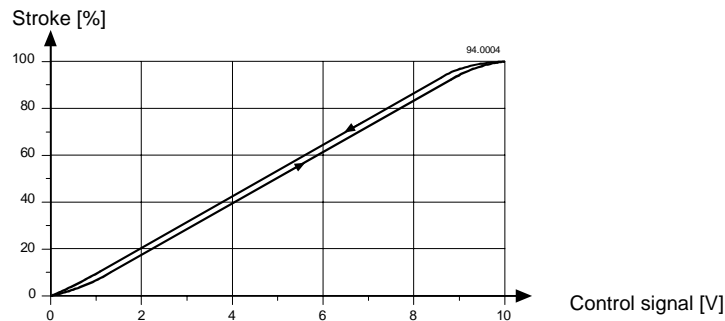

If the power is switched off or fails, the valve control path (port 1 → 3) is automatically closed by the force of the spring.

The valve stem is sealed with a maintenance-free O-ring gland.

Manual adjustment

Control path ports 1 → 3 can be opened mechanically to between 0 and approximately 90 %, by turning the handwheel clockwise. The manual adjustment facility can also be used as a mechanical method of low limit control, i.e. the valve will exercise its normal control function between the manually-set position and the 100% open position. For full-stroke automatic control, the handwheel must be set to 0 (the anticlockwise end-stop).

Accessories

- For flanged valves: Close off port '2' in straight-through applications.
The blank flange kit consists of a seal, screws, spring washers and nuts.
Z155/80 Blank flange kit for flanged valve with DN80
Z155/100 Blank flange kit for flanged valve with DN100
- See sheet CA1N4000E for a summary of valves for water and steam.

Sizing

Water flow chart

Flow / pressure differential relationship.

k_{vs} signifies the volume of water \dot{V} in m^3/h which flows through the open valve at a pressure differential Δp_v of 100 kPa (1 bar).

See data sheet CA1N4023E for notes on calculating the value of k_{vs} .

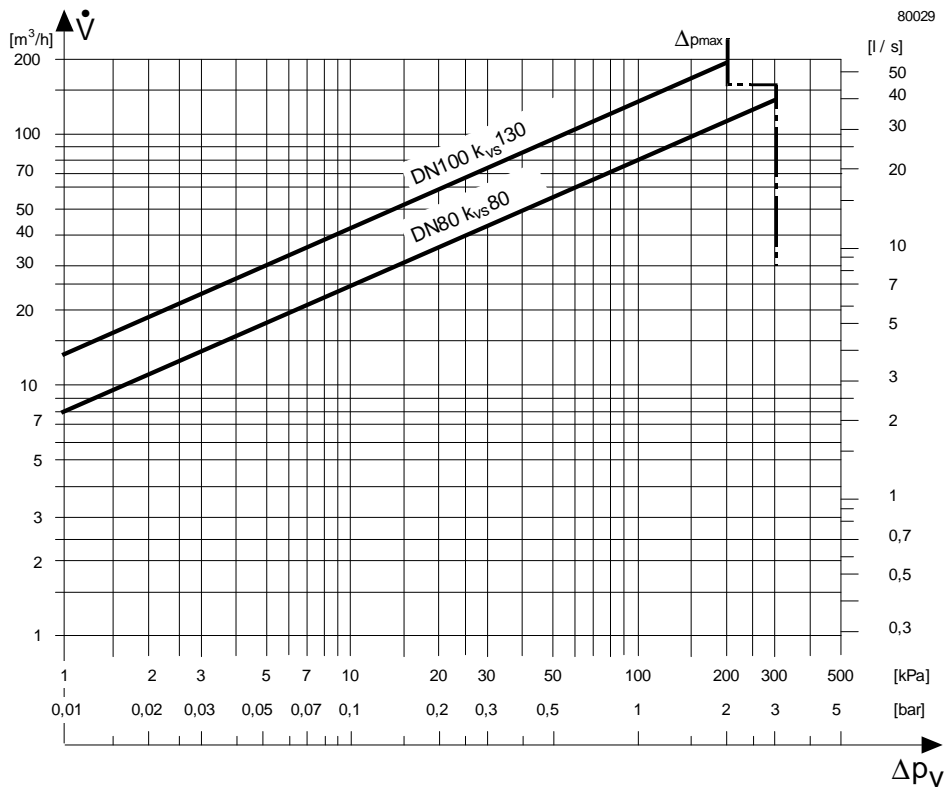

Mounting notes

Two mounting instructions are enclosed with the valve: Ref. 35638 (valve) and Ref. 35677 (terminal housing).

Caution : Always disconnect the power before fitting or removing the terminal housing. The terminal housing is calibrated and matched to the actuator, and should be replaced only by qualified personnel.

- The M3P...FY valve is suitable for straight-through or three-way applications but may be installed ONLY in a mixing arrangement.
- Vertical to horizontal mounting: Protection standard IP31.
The valve must not be suspended below the horizontal.
- The actuator must not be lagged.

Recommendation

Water systems should be cleaned, flushed and treated in accordance with current good practice, as described, for example, in BSRIA Application Guides AG 8/91 and AG2/93. For other relevant information, see also CIBSE Guide B (Section 7).

Straight-through applications

Close off port '2' with the type Z155/... accessories, which must be ordered separately. The blank flange kit consists of a seal, screws, spring washers and nuts.

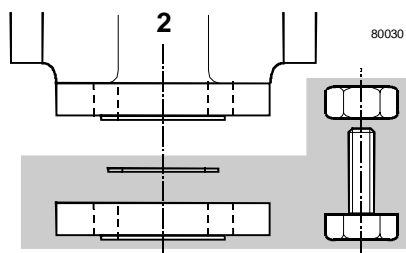

Technical data

Electrical interface

Power supply	Only admissible with low voltage (SELV, PELV)
Supply voltage	AC 24 V, 50/60 Hz
– Max. voltage tolerance	+15/–10 %
Nominal power	See table 'Operating data'
Control signal	DC 0 ...10 V or DC 4 ... 20 mA
Position feedback (output signal):	DC 0 ...10 V = 0 ...100 % stroke
Max. load	1.5 mA
Accuracy	± 3 % of full scale

Function data

Nominal pressure	PN16
Operating pressure $p_{e,max}$	1000 kPa (10 bar)
Pressure differential Δp_{max}	See table 'Operating data'
Leakage at $\Delta p_v = 0.1$ MPa (1bar)	
1 → 3	Max. 0.05 % kvs (to VDI/ VDE2174)
2 → 3	Depends on application data (approx. 2 % kvs)
Valve characteristic (stroke, k_v)	Linear, optimised in low-opening range
Resolution $\Delta H / H_{100}$	> 1 : 1000 (H = stroke)
Type of operation	Modulating
Manual adjustment	0 % to max. 90 % depending on DN
Position when de-energised	1 → 3 closed
Orientation	Upright to horizontal
Positioning time	1 s

Electrical connection

Connection terminals	Screw terminals for 4 mm ² wire
----------------------	--

Ambient conditions

Ambient temperature	2 ... 50 °C
Water temperature	2 ...120 °C

Materials (valve body)

Housing	Cast iron
Inner valve	CrNi steel
Seat	Brass
Valve spindle seal	EPDM (O-ring)

Dimensions / Weight

Dimensions	See table in section 'Dimensions'
Weight (incl. packaging)	See table in section 'Dimensions'

Safety

Protection standard	Upright to horizontal mounting IP31 to IEC529
Conformity	Meets the requirements for CE marking

Internal diagram

NS = system ground

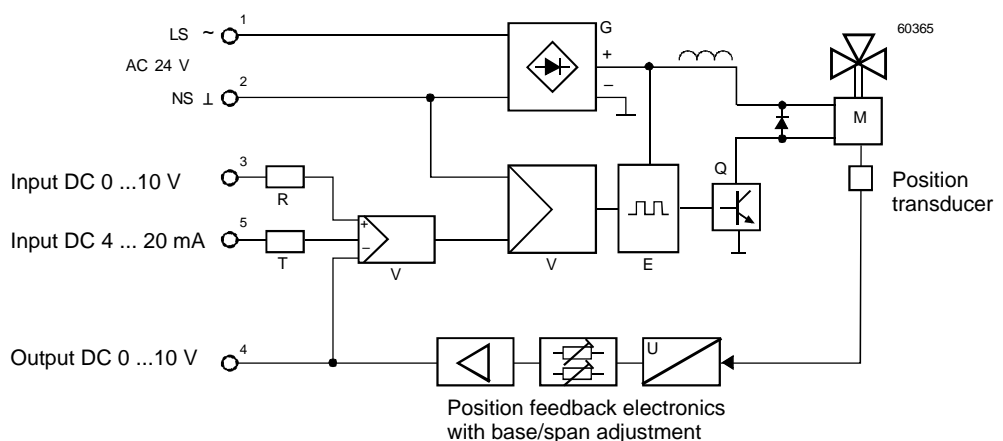

Block diagram of the signal converter

Key to block diagram

E	Phase cut converter	R	Input resistor 50 k ohms
G	Bridge rectifier	T	Voltage / current converter (load on 350 ohms to NS)
M	Magnetic valve	U	Position / voltage converter
Q	Phase cut output	V	Differential amplifier

Connection terminals

Warning : If the controller and the valves receive their power supply from separate sources, the valve transformer must not be earthed on the secondary side.

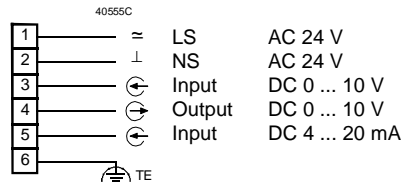

Connection diagrams

• with DESIGO 30

– refer to manual R21

• with INTEGRAL RS

– refer to manual K21

• with MULTIREG

Warning : The transformer T2 must not be earthed on the secondary side and should be suitably fused.

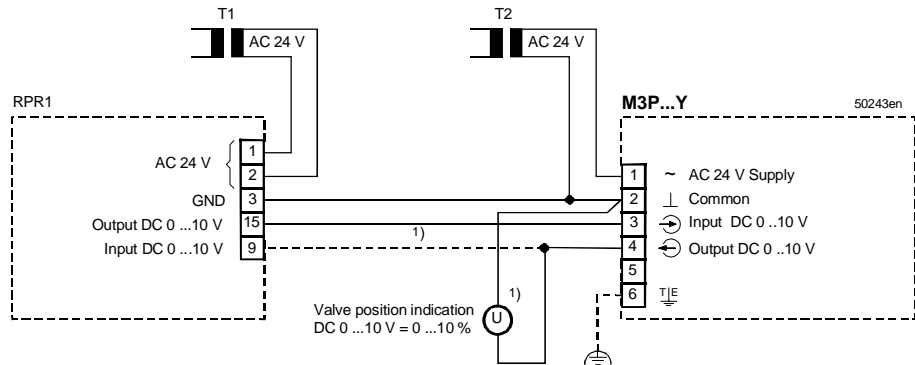

• with other controllers
(output DC 0 ... 10 V)

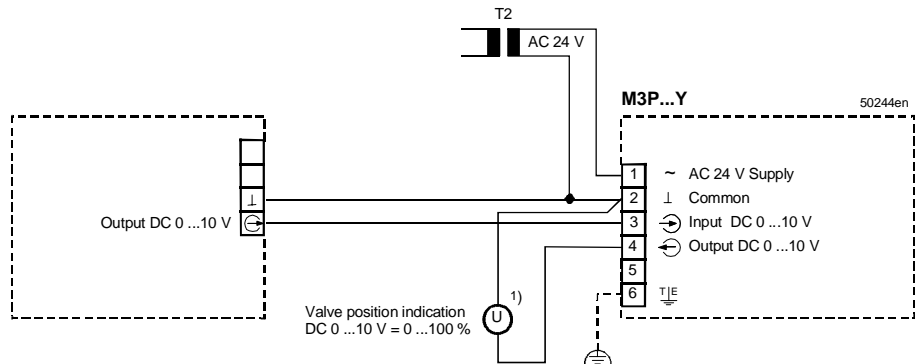

1) only where required

• with other controllers
(output DC 4 ... 20 mA)

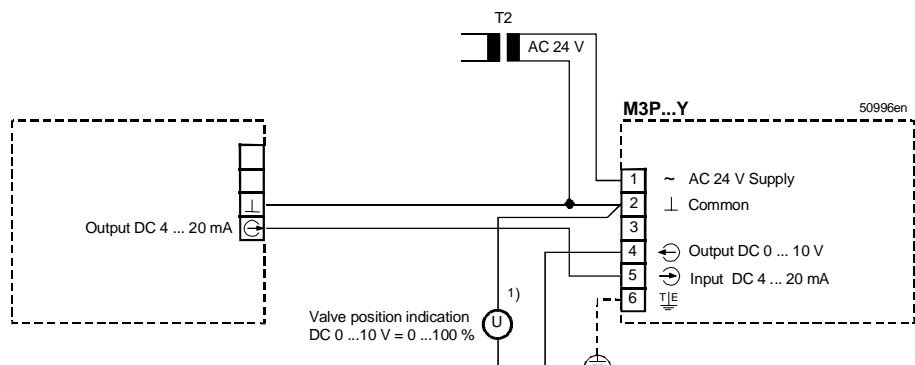

1) only where required

Application examples

The hydraulic circuits shown here are schematic diagrams only, without installation-specific details.

Warning : The valve is suitable for straight-through or three-way applications and may be installed ONLY in a mixing arrangement.

Hydraulic circuits

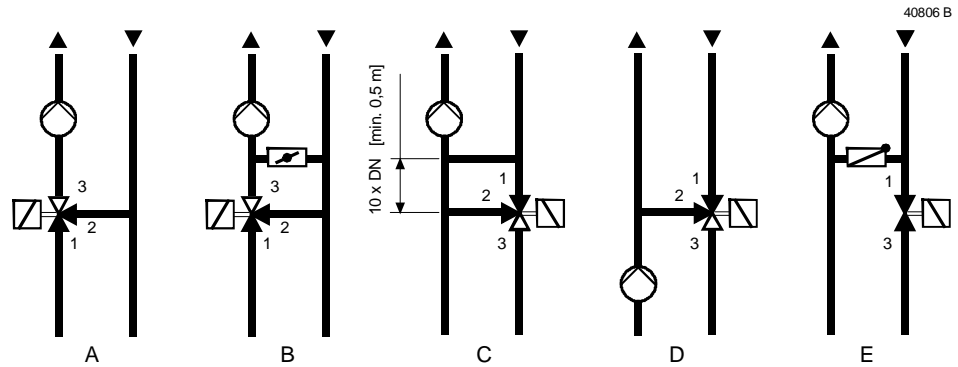

Legend

- A Mixing circuit
- B Mixing circuit with bypass (underfloor heating)
- C Injection circuit
- D Diverting circuit
- E Injection circuit with straight-through valve

Dimensions

All dimensions in mm

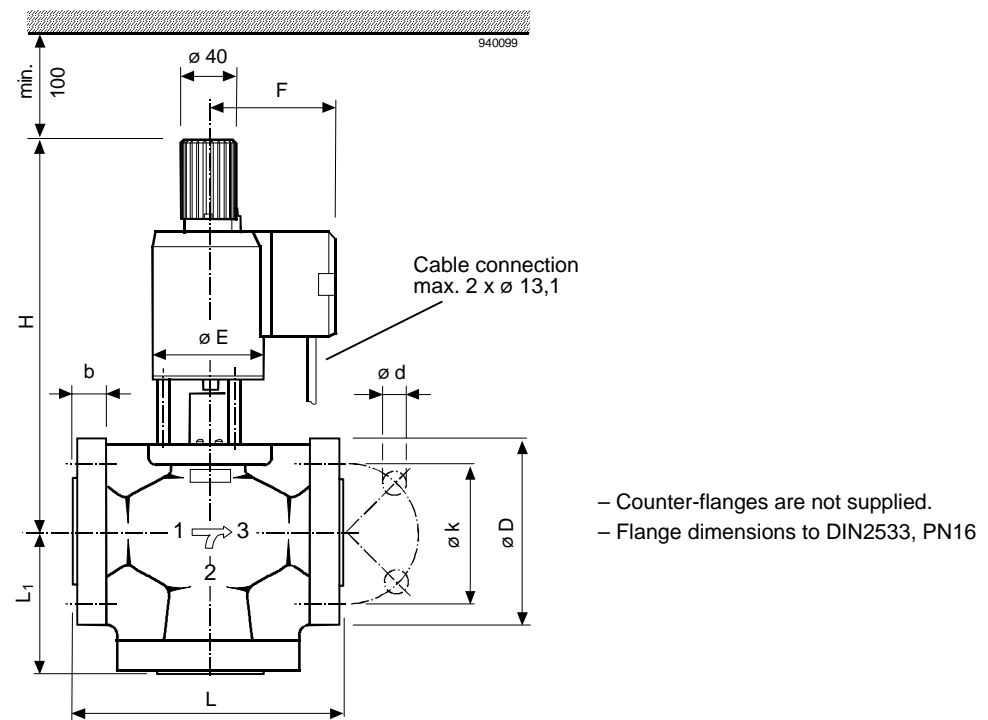

Valve type	L	L ₁	D	b	k	d	H	E	F	W
M3P80FY	310	140	200	22	160	8x18	508	145	124	45.5
M3P100FY	350	160	220	24	180	8x18	570	145	124	59.0

W = Weight in kg (incl. packaging)